

ProWave Swivel Lock - SLC

The Swivel Lock can be fitted to the ProWave range of Fixed Pedestals which allows you to swivel 360 degrees. The front clamp is lockable in any position.

PROWAVE



SPECIFICATIONS

Height:	130mm
Width:	182mm
Length:	171mm
Material:	GF Nylon
Finish:	Black Composite
Product Weight:	0.92kg

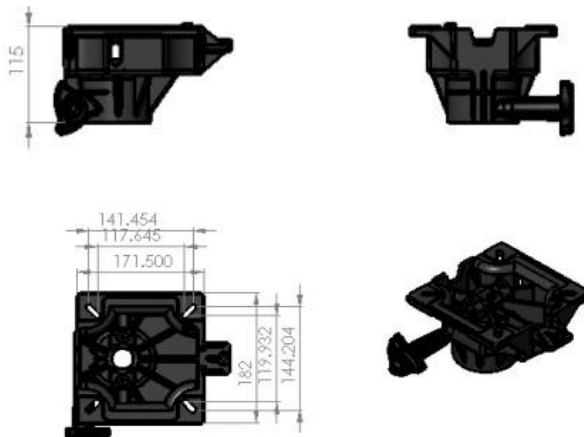

Note: Marine Tech Industries has the expertise to custom design & build products to specific requirements.